

**A STUDY OF**  
**SHELL TO SHELL**  
**CONDUCTIVITY**  
**AND**  
**MEASUREMENT**  
**TECHNIQUES**  
**FOR COMPOSITE**  
**CONNECTORS**

**PREPARED BY:**  
**Amphenol Corporation**  
**Amphenol Aerospace Operations**  
**40-60 Delaware Street**  
**Sidney, NY 1383**  
December 3, 1998

## **Background:**

The shell to shell connector conductivity test is defined by Mil-Std-1344 method 3007. This procedure describes a generic method for testing which requires creative interpretation and exercise of test techniques. The method describes the use of a voltmeter ( $\pm 2\%$  of full scale accuracy), ammeter (1% accuracy), power supply (1 ampere  $\pm .1$ ), test probes (.050 inch minimum spherical radius) and fixture (non-conductive). It then states to apply the current of 1 ampere maximum at 1.5v volts dc maximum across the connector and measure the millivolt drop at points described by the individual connector specification with the .050 inch minimum radius probes.

## **The Problem:**

The problem that occurs from the creative interpretation is that a variety of test techniques have been incorporated to determine the conductivity of a mated connector. Where in fact, the whole purpose of the testing is to determine the true ability of the mated connector to carry current, the test becomes one of “technique” rather than connector performance.

The question of application of current arises. This may appear to be obvious, but it is not. The current should flow through the connector from one end to the other. It could be applied using an alligator (or similar) clip on the end of the connector shell. This presents a number of questions: Do you place the clip on the castellations or the threads? How far onto the shell do you place it? Maybe a band should be used to distribute the current more evenly around the shell. If you use a band, how much force should it exert? Where should it be placed? Around the castellations or the threads? How far up the shell? Maybe a pressure pad on the end of the shell should be used this will then interface with the tops of the castellations and distribute current evenly. How much pressure should it exert on the shell to assure good contact? Should the pressure be the same for mated connectors and/or shell components? As the reader can see, there is a great variety of ways to just apply the current.

A similar problem is inherent in the probing of the connector. It is not always clear where the pick up points should be or how far apart the probes should be or how much pressure the probes should exert. This is especially true when the probes are not spring loaded and are subject to technician hand pressure. Some connector finishes are sensitive to probe pressure and probe finish.

## **Solution:**

The solution would then be to define a test method and fixture that would give a true picture of the connector performance and take away the creative interpretation. In doing this, there would result a standardized test procedure that all would use to obtain similar data. The variability in the technique would be eliminated and more consistency in the results from various test houses would result. The fixture would have to eliminate both the subjective nature of the testing and any technician judgment. It would also have to be independent of technician technique.

Amphenol has worked on this problem and proposes a test fixture that takes away inconsistencies in technique and operator variability. It provides all the criteria to take “the people factor” out of the testing and the test results.

## The Fixture:

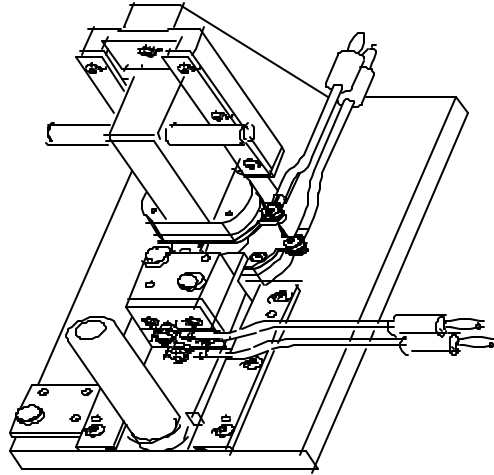

Amphenol designed a test fixture that controls variances in the set up, application of the current and reading of the millivolt drop. The test fixture applies uniform and consistent pressure on the ends of the shell components/or mated connectors (Note: The force has to be sufficient to make good contact but not so high that it drives the mated connector together). It also applies consistent pressure and distance for the pick up probes which measure the millivolt drop.

The current is applied through a weighted slide mechanism with plated gauze pads. The weighting of the slide assures that the pressure is the same each time the test is run. The gauze pads “mesh” with the castellations and assure uniform distribution of the current over the diameter of the part. The gold plating assures a clean conductive surface each time the test is performed.

The test probes are spring loaded to apply the same pressure each and every time a test is performed. The probes are contained in a dielectric block that separates them to consistently apply the probing distance. The probes are gold plated with a .050 inch spherical tip (0.100 diameter probe) to assure a clean and consistent pick up.

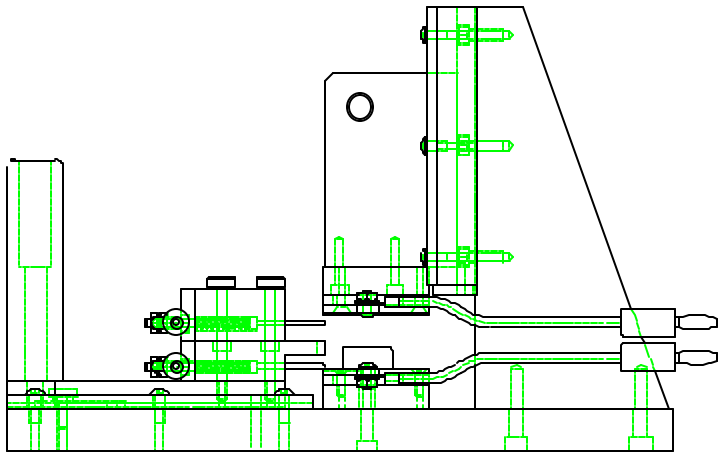
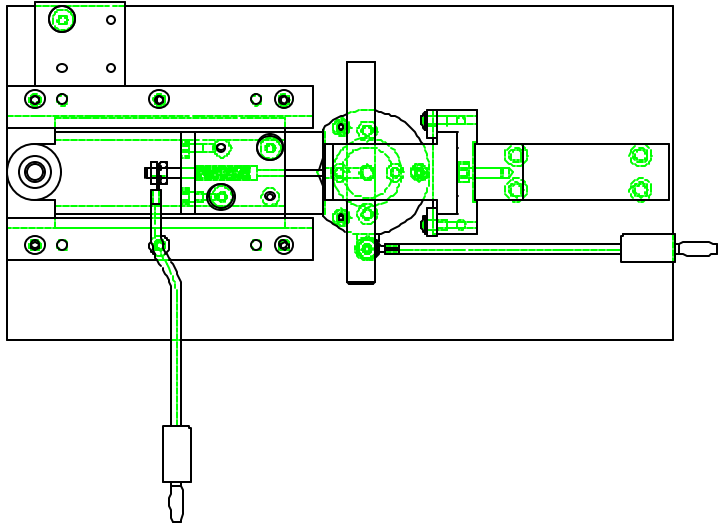

## **Results:**

Several tests were performed using various techniques prior to determining the effectiveness of the fixture. The progression of the test techniques follows:

1). Alligator clips were used to apply the current and the millivolt drop was measured by probing with hand pressure. This resulted in inconsistent readings depending on where the alligator clips were placed and how much pressure was applied to the probes. The alligator clips were placed on opposite ends of the connector in line on the same plane or 180° off on the opposite end. They were attached to the castellations and also to the threads. The probes were applied by hand.

2). Bands were placed around the back of the connector to apply the current and the millivolt drop was measured by probing with hand pressure. This resulted in inconsistent readings depending on where the bands were placed and how much pressure was applied to the probes. The bands were placed on opposite ends of the connector, they were attached to the castellations and also to the threads. The probes were applied by hand.

3). The connectors were also placed in a vise between pressure pads to apply the current with the millivolt drop measurement being made by probing with hand pressure. This was an improvement over the alligator clips and the bands but was highly dependent on amount of pressure exerted by the vise.

4). A wire mesh was inserted into the vise over the pressure pads to give better distribution of the current and take up some of the pressure variances exerted by the vise. The probing was still done with hand pressure. More consistent values were obtained but some inconsistencies were still noticed.

5). This led to a weighted fixture without wire mesh and probing with spring loaded probes. This displayed very consistent values but somewhat higher than the wire mesh in the vise.

6). The fixture was then modified with gold plated wire mesh and probing with spring loaded probes. This fixture then displayed very consistent values that were equivalent to the lowest values obtained by the other methods.

The following is a set of sample data taken using various techniques using the same nickel plated composite connectors:

Sample Type	Sample Identification	C Vise with (Wire Mesh)	D Alligator Clips	E Test Fixture (NO Gauze)	F Test Fixture (With Gold Plated Gauze)	C-F
Plug	1	0.82	2.20	1.37	0.91	-0.09
	2	1.34	2.50	0.98	0.84	0.50
	1T	0.94	2.30	1.57	0.85	0.09
	2T	0.75	2.40	1.22	0.73	0.02
	3T	0.86	2.40	1.16	0.70	0.16
	4T	0.88	2.20	1.31	0.72	0.16
	5T	0.85	2.60	1.33	0.60	0.25
Receptacle	1	0.67	1.70	0.30	0.39	0.28
	2	0.80	1.70	0.63	0.27	0.54
	1T	0.55	1.60	0.74	0.55	0.00
	2T	0.69	1.60	0.31	0.55	0.14
	3T	0.72	1.70	0.43	0.45	0.27
	4T	0.64	1.60	0.60	0.54	0.10
	5T	0.57	1.60	0.60	0.53	0.04
Mated	1	1.16	2.70			
	2	1.37	2.80			
	1T	1.10	2.50			
	2T	1.26	2.70			
	3T	1.30	2.90			
	4T	1.75	2.80			
	5T	1.19	2.80			

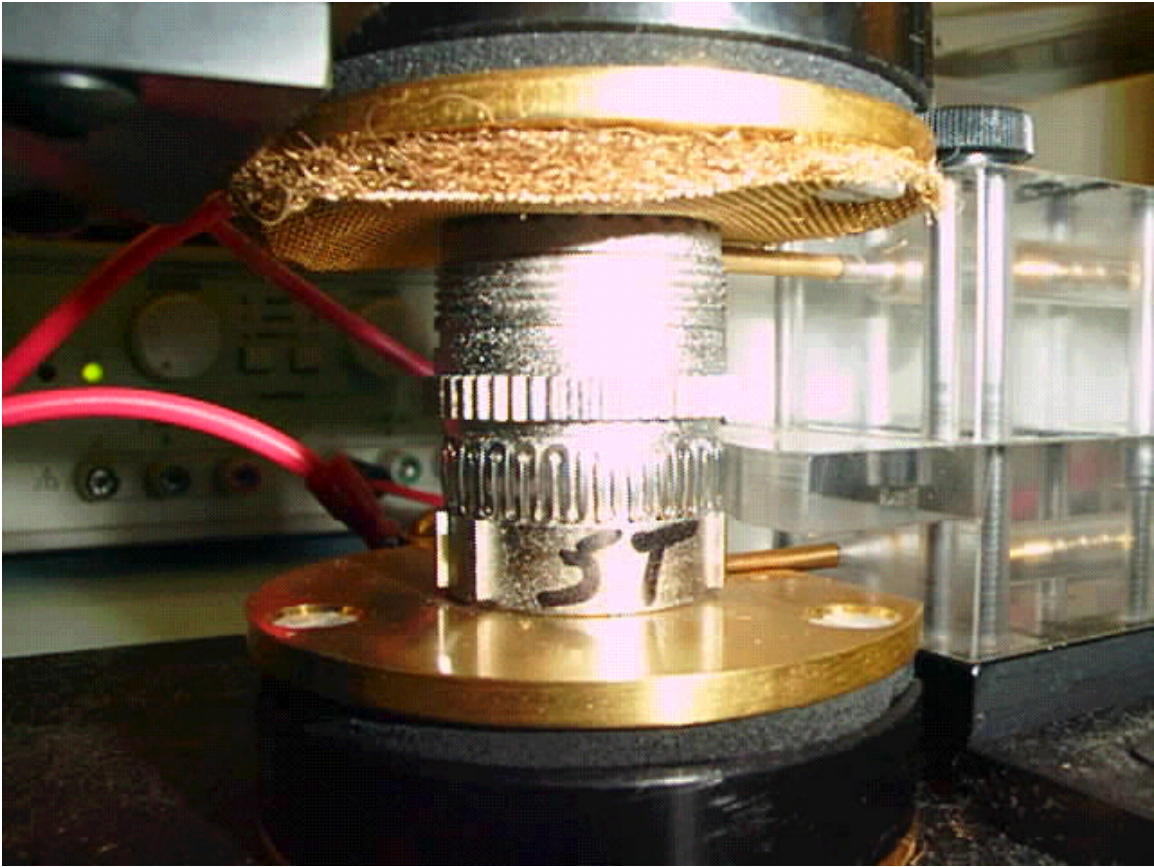

## **Plug Shell Under Test**

### **Conclusion/Recommendations:**

This study resulted in a uniform test fixture and method (independent of technique) which produces repeatable and accurate results. This fixture and technique eliminates most variables which affect results. The proposed fixture/technique is applicable to most cylindrical connector types and finishes.

It is recommended that the proposed fixture and technique be distributed to the user community and comments coordinated. It is also recommended that the results be incorporated into Mil-Std-1344 Method 3007 for use with plated, composite connectors.

